

## Advantages of ARMIS ONE 2024:

- ✓ Barrier does not obstruct passage for pedestrians, cyclists and wheelchair users.
- ✓ Optimal escape route width of 1.2 metres between the barrier segments.
- ✓ Certified as a single module according to ISO 22434-1 / DIN SPEC 91414-1.
- ✓ Secure and resistant to vandalism and manipulation.
- ✓ No supervision or guarding necessary.
- ✓ Simple manual lowering/folding of the barrier segments for controlled passage of emergency vehicles.

## Technical drawings:

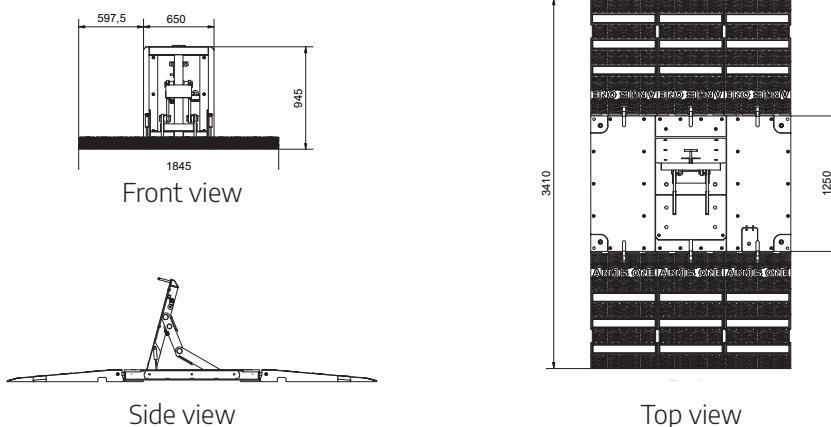

## Certification:



Fahrzeugklasse

**N2A LKW**

**7.2t**

Anprallwinkel

**90°**

Fahrzeugeindringtiefe

**8.3m**

**48 km/h**

Anprallgeschwindigkeit

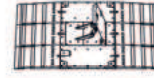

Test	Penetration depth	kJ   km/h	Weight	Angle of impact	Vehicle class	Number of elements
ISO 22343-1:2023	8.3 m	634.0   48.0	7,200 kg	90°	N2A	1

Fahrzeugklasse

**N2A LKW**

**7.2t**

Anprallwinkel

**90°**

Fahrzeugeindringtiefe

**8.3m**

**48 km/h**

Anprallgeschwindigkeit

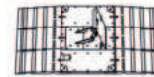

Test	Penetration depth	kJ   km/h	Weight	Angle of impact	Vehicle class	Number of elements
DIN SPEC 91414-1	8.3 m	634.0   48.0	7,200 kg	90°	N2A	1

Manipulation test acc. to DIN SPEC 91414-1 passed. 0.1 m / MK2.

## Logistics concept:

Stackable heavy-duty pallets for secure transport and space-saving storage.

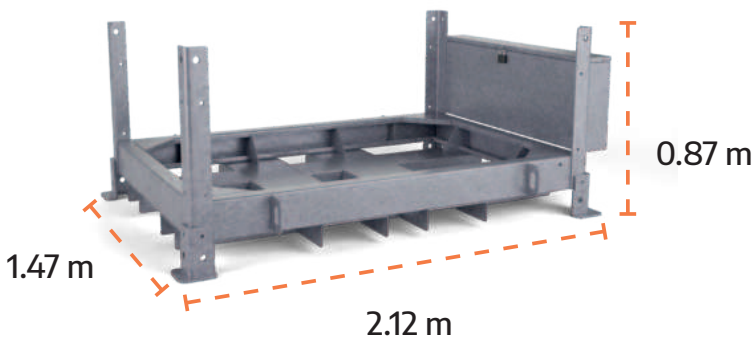

Weight excl. barriers	230 kg
Weight incl. barriers	1,770 kg



More information  
**Scan QR Code**  
[www.access-barrier.com](http://www.access-barrier.com)

**fsb@volkmann-sv.de**

**+49 2602 9470 0**

Hohe Strasse 9-17 | 56410 Montabaur | Germany